



Audi India
Division of Volkswagen
Group Sales India Private Limited
Mumbai - India
www.audi.in
Valid from January 2015

The models and equipment versions illustrated and described in this brochure and some of the services listed are not available in all countries. Some of the cars illustrated are equipped with optional features for which an extra charge is made. Details concerning the delivery specifications, appearance, performance, dimensions and weights, fuel consumption and running costs of the vehicle were correct to the best of our knowledge at the time of going to press. Deviations from the colours and shapes shown in the illustrations may occur. No liability is accepted for errors and printing errors. The right to introduce modifications is reserved. Not to be reproduced, including in part, without the written approval of AUDI AG.

Printed in India
TT DJ 1

U50401MH2007FTC168439

Audi TT Coupé

TT
Audi TT Coupé

Vorsprung durch Technik 



	Page	Page
Emotion		
Technology	01 The Audi TT Experience	
	18 Innovations	28 Assistance systems
	20 Audi ultra	30 Simplicity
	22 quattro®	32 Audi virtual cockpit
	24 Intelligent performance	
	26 Dynamics	
Equipment		
	38 Engines	Steering wheels/controls
	39 S line	Comfort
	40 Audi design selection	Infotainment
	42 Audi exclusive	Assistance systems
	44 Exterior	Technology/safety
	Paint finishes	66 Audi Genuine Accessories
	Wheels/Tyres	69 Dimensions
48 Interior		70 Technical data
Seats		72 The fascination of Audi
Upholstery		
Inlays		
54 Equipment		
Light		
Design		



Future



TT

Audi TT Coupé

Audi virtual cockpit. High-tech at the highest level. Premiered in the new Audi TT Coupé. The driver determines how the instrument cluster – a high-resolution LCD screen – presents information: either as classic round dials or through futuristic full-screen views. Driver-focused. Innovative. Progressive. Easy to switch via the multifunction steering wheel. For a quick change of context. A clear statement of the technological benchmark in the new Audi TT Coupé.

starts here.





Stand out.



A silhouette that sets itself apart. Unequaled. Both in the past and now. The new Audi TT Coupé – yet another milestone in the success story. Its whole appearance is energetic – from the horizontal design of the vehicle's rear to its taut surfaces. Dynamic and athletic. Just like a body defined down to the last detail. Low, wide, stretched. No superfluous lines. Absolute precision, single-mindedly pursuing a clear aim: to impress with powerful aesthetics. The new Audi TT Coupé – one of the most progressive sports cars of our time.



Different



A body line that takes up the design of the first Audi TT Coupé – and consistently refines it. A statement. Shaped by pure design. Crisp edges indicate strength of character. Powerfully staged. With striking air inlets. The new three-dimensional design of the Singleframe is integrated stylishly in the horizontal front end. The Audi rings on the bonnet. A position that indicates its sports car genes and immediately sets your pulse racing. Numerous details round off the appearance. Take the tank cap in aluminium design with visible screw thread. Streamlined. Sporty. A tribute to its predecessors. Yet still a completely new creation.

way of thinking.

M a k i n g

Visibly more expressive. Thanks to the optional Audi Matrix LED headlights in 3D design with characteristic horizontal and vertical elements. Starting at the front and continued visually in the Singleframe and on the bonnet. Futuristic, progressive. Made up of single light emitting diodes, recognising oncoming traffic and optimising the illumination of the surrounding area. The rear end causes a stir too. Equipped with LED technology as standard and with a continuous brake light. The light concept of the new Audi TT Coupé – design language that needs no translation.

a m a r k .





Focus on the



The interior of the new Audi TT Coupé: remarkably expressive. Because it combines design, sportiness and maximum comfort. Personalise it. By way of coloured interior elements on the centre console, for instance, or seats and vents in turbine design. Convincing and top class. Just like the optional S sport seats – available for the first time in the new Audi TT Coupé. Plus innovative and intuitive air-conditioning controls in the dashboard. All with the aim of concentrating at all times on the most important thing: driving.

essentials.

Take



Even sportier, even less compromising. With the new quattro® permanent all-wheel drive. Making dynamic driving in the new Audi TT Coupé even more controlled. Precise and gripping. For this, the drive force is distributed variably to the axles. With a rear emphasis. Thus profoundly maximising driving enjoyment. Thanks to special tuning for even sportier lateral dynamism. And for improved vehicle specific driving behaviour. Where you set the course.

control.





Remain



Increase torque every moment. Powerful and efficient engines incessantly power the new Audi TT Coupé to maximum performance. State-of-the-art transmission technology guarantees fast gear changes. A complex lightweight engineering concept reduces consumption, increases efficiency and further lowers the centre of gravity – thus improving handling. Experience limitless driving enjoyment.

uncompromising.



Standards



redefined.

The new Audi TT Coupé. An icon returns.

Audi ultra

Perfectly combined.

The future of efficient technologies.

Building an Audi is an extremely complicated business. And yet a simple principle applies for all models: all vehicle components interlock precisely in order to produce emission-reducing synergies. What started in accordance with this principle at the end of the 1980s with Audi lightweight construction and the revolutionary Audi Space Frame (ASF®) is now known as the reversal of the weight spiral: every lightweight component has an impact on other components, which can in turn be made smaller. In this way, existing forms and materials are continuously being improved with regard to their functionality, the lowest possible weight and their production process. With the goal of building vehicles that are even more efficient and make more sparing use of resources. At the same time, more and more efficiency technologies are being built into an Audi. These include recuperation and the start-stop system. Not to mention progressive, efficient high-tech engines. For greater driving dynamics, high compression, more efficient combustion and lower CO₂ emissions. All this is known as Audi ultra. Today and in the future – towards CO₂-reduced mobility.

>>> Aerodynamics

Less drag, more efficiency. Thanks to the consistently aerodynamic styling of the vehicle's lines, its underbody and spoiler edges – in order to achieve the best possible form for aerodynamic efficiency. Not forgetting tyres with reduced rolling resistance. All tested in the Audi wind tunnel at up to 300 km/h.

>>> Lightweight expertise

Less weight. More savings, power and endurance. Audi lightweight technology. What started with lightweight body construction has now made its way into nearly all areas, combining innovative materials such as aluminium and magnesium, intelligent design principles and resource-saving manufacturing processes into an overall concept.

>>> Recuperation

Braking that leads to even more efficient driving. With brake energy recovery (recuperation). Part of the kinetic energy produced when braking and coasting is temporarily stored in the vehicle's battery and then used when accelerating. Depending on the driving cycle, this can save up to 3% of fuel.

>>> Transmission expertise

Improved efficiency thanks to improved transmission ratios. A higher torque output makes longer ratios possible, especially in higher gears. For powerful torque in the low engine speed range which reduces consumption – yet has no adverse effects on driving performance and sportiness.

>>> Engine expertise

Powerfully and efficiently driven. By Audi ultra with efficiency technologies in the engine sector.

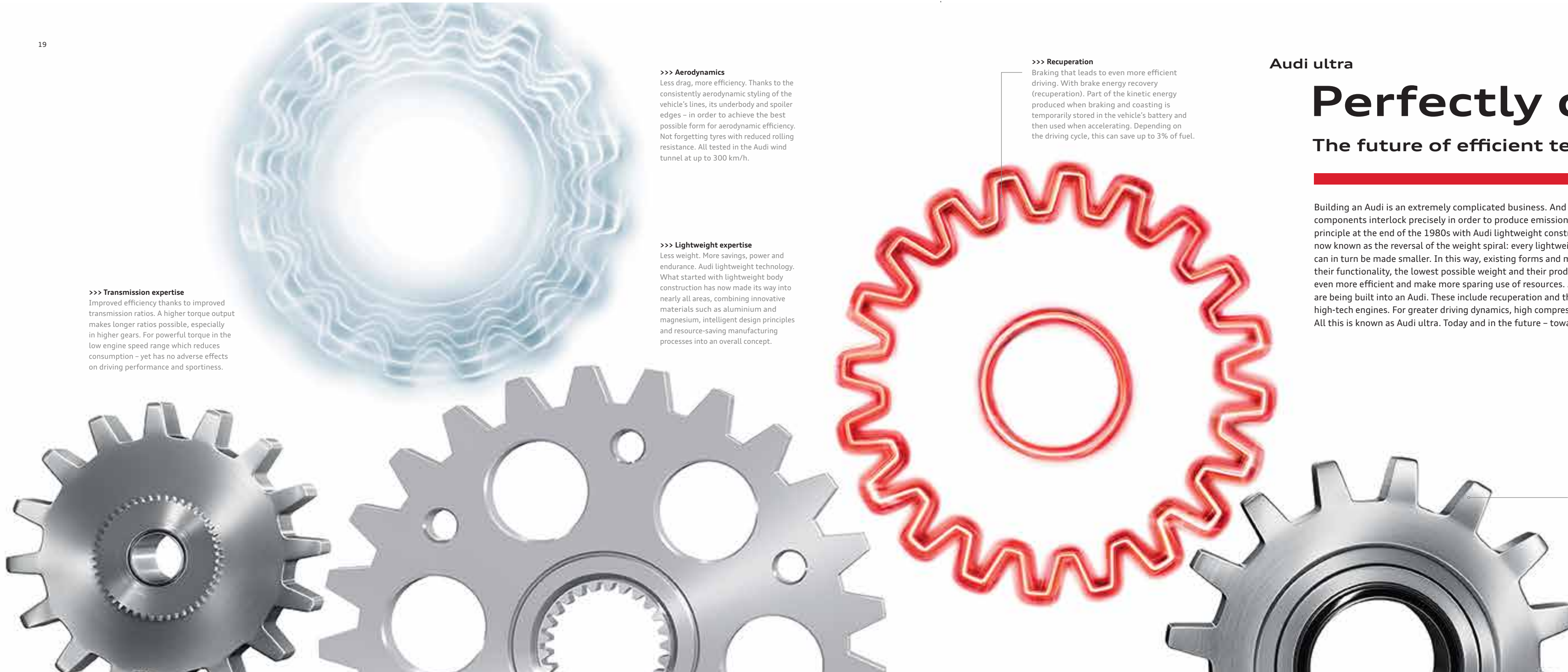



Have the road completely under control, thanks to permanent distribution of the drive force to all four wheels. The rear axle is variably controlled via a hydraulic multi-plate clutch. Always as the situation demands, always selective. Optionally, with rear emphasis. Experience handling stability, dynamism and agility as never before and combat the effects of over - and understeer with quattro®. For increased traction and superior propulsive power. Tame any road. And always keep your eyes set on where you're heading. In bends. On straights. Over any surface. For a fascinating experience that sticks. To the road - and in your mind.



quattro®
**Stick to
the road.**

With quattro®.

Intelligent performance

Maximum power. Put to maximum use.

Every movement originates from something. Something that sets it off, an idea. The engine in your Audi can also be traced back to an initial spark of inspiration: higher power with lower fuel consumption. These apparently conflicting aims are united in the revolutionary drive technology: TFSI®.



TFSI®

Audi TFSI® engines attain a particularly high compression rate. The result: outstanding efficiency combined with optimum performance. Substituting supercharging for cubic capacity has the effect of considerably reducing engine size and weight - while performance remains as impressively dynamic as ever. For power delivery that will win you over from the word go.

>>> Audi drive select®

Audi drive select® lets you adapt the driving characteristics of your Audi to your requirements. At the push of a button. Sportier, more comfortable, more balanced or more economical. It's entirely up to you.

>>> S tronic®

The sporty, efficient dual-clutch transmission allows you to switch gears with lightning speed without any perceptible break in propulsive power.

>>> Electromechanical power steering

Through the speed-sensitive steering assistance, the power steering conveys a precise steering feel even at high speeds, helps you to countersteer and makes light work of parking.

>>> Progressive steering*

Enhanced driving dynamics due to a more direct steering ratio as well as increased driving comfort in everyday driving conditions due to reduced steering effort. The progressive steering provides you with impressive driving characteristics thanks to the variable power steering assistance based on the steering angle.

>>> quattro®

The permanent all-wheel drive system distributes the drive forces to each individual wheel according to the driving situation for extra traction and dynamic performance.

Dynamics

Dynamics

that will take hold of you.

Get in. Buckle up. Start the engine. Wherever you're heading, enthralling driving dynamics will power you there. For as you know, the world is your oyster once you get behind the wheel of your Audi. You decide the direction. The driving style. The pace. And you enjoy the satisfaction of knowing you have plenty in reserve. More than enough to get the very best from every drive.

Assistance systems

Wherever you're heading, peace of mind will be your constant companion.

With the assistance systems in your Audi.

Each drive is different. Yet they all have one thing in common – the feeling of being protected that you get from every Audi. All driver assistance systems in your Audi help you during your journey and guarantee even greater comfort when you're on the road. Get to know the most important driver assistance systems.

>>> Secondary collision brake assist

prevents the vehicle rolling away uncontrolled after an accident in certain situations and can avoid secondary collisions in these cases.

>>> Audi Matrix LED headlights

track the road ahead and illuminate it according to the situation with their innovative LED layout for even greater safety.

>>> Parking system plus

provides a better overview for parking and manoeuvring by showing visual displays of the vehicle's surroundings.

>>> Park assist

helps you to manoeuvre into parallel and perpendicular parking spaces as well as out of parallel parking spaces again with a virtually automatic steering process.

Please note: The systems work only within system limits and assist the driver. However, the driver remains responsible for driving the vehicle and is required to be attentive at all times.

>>> Car

Control and alter driver assistance systems, vehicle settings as well as climate control and service functions quickly and easily.

>>> Media

Display the covers of your music collection on all available media sources such as jukebox, inserted SD cards, Audi music interface, CDs or DVDs.

>>> Sport leather steering wheel with multifunction

Keep everything under control. The Audi virtual cockpit and numerous MMI® functions can be operated ergonomically from the TT sport leather steering wheel with multifunction fitted as standard.

>>> MMI® touch

Operate the individual components of the Multi Media Interface (MMI®) even more easily using the MMI® touch. The touch function integrated in the rotary/push-button can also be controlled by means of handwriting recognition and, like a smartphone, with multi-touch gestures. 2 function keys are all you need for selections in the basic menu and the context-based options. Two toggle switches provide direct access to the phone, navigation/map, media or radio.

>>> Navigation

With MMI® navigation plus with MMI® touch you can let yourself be guided to your destinations with even greater ease by the 3D map view and 3-dimensional display of places of interest and landmark buildings.

>>> Phone

Make phone calls safely and easily using the hands-free facility: simply select the number to dial from your contacts in the MMI® or enter the number intuitively via the optional MMI® touch.



y

u

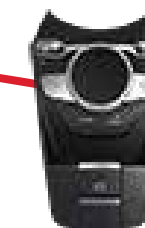

Simplicity

The MMI® – intelligent, individual, intuitive.

Streamlined. Simple. Logical. The world of mobile infotainment completely redefined: the Multi Media Interface (MMI®). Phoning or navigating all highly intuitive, highly functional and highly convenient – not least thanks to voice control and brilliant representation via the Audi virtual cockpit in the new Audi TT Coupé. With MMI® radio or the optional MMI® navigation plus with MMI® touch, everything will be child's play for you.

Audi virtual cockpit

Concentrated.



>>> Classical

High-resolution, razor sharp. The large round instruments for speed and engine speed are emphasised with this display version. The space between is used for additional information.



>>> Progressive

When you switch to the small display of the round instruments, the 12.3-inch colour display is turned into a vast stage. The navigation map, for example, is displayed as a 3D terrain model in full width and impressive brilliance.



>>> Versatile

The innovative, fully digital instrument cluster displays the respective information flexibly and according to requirements. Map representation, radio/media information and much more besides – with clear graphics and intuitive menu structure.



Focused.

Extraordinarily clear. The new instrument cluster. Brilliantly designed, brilliant resolution and representation. Unparalleled innovation. And intuitive right from the word go. It can be used to control all functions and MMI® services. From onboard computer to navigation. This is pioneering technology. The LCD screen has place of pride in the dashboard. At an optimum viewing height for the driver. There is a choice of two display variants: classical or progressive. Switch conveniently using the TT sport leather steering wheel with multifunction. Simply impressive. Further proof of Vorsprung durch Technik.



As unique as you are.
The equipment options.

Sportiness, comfort, design, functionality – whatever you demand of your Audi, it offers you a wealth of custom options. Audi equipment versions are varied and high-quality and you can tailor them entirely to your needs.

Character takes on many forms. Here is one!!

What makes an Audi your Audi? Vehicle equipment entirely tailored to your needs. There are a wide range of options available to you for giving your vehicle the exact touch you have in mind. More sportiness? More elegance? Let yourself be inspired.

Audi TT Coupé in Vegas yellow

Audi Sport cast aluminium wheels in 5-twin-spoke design in matte titanium look, gloss turned finish

S sport seats in fine Nappa leather, rotor grey

Inlays in matte brushed aluminium

Bang & Olufsen® Sound System

TT sport contour leather steering wheel with multifunction plus

S line exterior package

S line sport package



The right driving force for every personality.

The 2.0 TFSI® has a high compression ratio, highly efficient combustion and outstanding efficiency. In short, it delivers more power whilst using less fuel and producing fewer emissions.



2.0 TFSI®

TFSI®

The Audi TFSI® engines offer outstanding efficiency and improved performance whilst at the same time retaining their dynamism. The 2.0 TFSI® quattro® in the new Audi TT Coupé, for example, has a power output of 169 kW, enabling the car to accelerate from 0 to 100 km/h in 5.3 seconds and reach a top speed of 250 km/h.

TT Coupé 2.0 TFSI® (169 kW)

Remaining faithful to the sporty line: the S line packages.

The S line packages emphasise the sporty character of your Audi TT Coupé. Accentuate the dynamic body line, lend the interior even more expression or give the suspension even sportier definition for enhanced driving dynamics. And make a true athlete of your Audi.



S line exterior package*

Front and rear bumpers, side sill trims, side radiator grilles and diffuser insert in distinctive sporty design

Radiator grille in high-gloss black

Diffuser insert painted in platinum grey

Door sill trims with S line logo

S line emblem on the front wings

As unmistakable as your own standards: the Audi design selection.

The Audi design selection offers you an aesthetic pre-selection of particularly exclusive materials and colours for the interior. The aluminium drift anthracite inlay in conjunction with the fine leather upholstery and trim in murillo brown or admiral blue with attractive contrasting stitching gives the interior a sporty and exclusive ambience.



Audi design selection murillo brown* (TT Coupé)

The Audi design selection murillo brown includes the following equipment items:

S sport seats, front
 Seat centre panel, seat side bolsters and head restraints in fine Nappa leather, murillo brown, with contrasting stitching in steel grey; seat centre panel with diamond pattern
 Door/side panel trim inserts in fine Nappa leather, murillo brown
 Centre armrest in leather, murillo brown, with contrasting stitching in steel grey
 Armrests in the doors and door pull handles, centre console trim and instrument panel cover in leather, stone grey, with contrasting stitching in murillo brown
 Steering wheel collapsible collar trim in black leather
 Accent floor mats in black-murillo brown with piping in black
 Coloured interior elements in chrome coating, slate grey, on the side seat trims, the striking handle on the centre console and the inner rings of the vents
 Inlay aluminium drift anthracite
 Optionally available with pneumatic adjustment of the backrest side bolsters



*Optional

You have an exclusive character. So why shouldn't your Audi have one too?

That the Audi exclusive range aspires to exclusivity is already evident from its name. Coloured leather can be combined with customised paint finishes from the large selection of Audi exclusive colours to suit your own personal preferences. So you can highlight your car's exceptional character to even better advantage. Your Audi partner and the Audi exclusive Studio of the Audi Forum Neckarsulm, Germany await your wishes.



Audi exclusive is from quattro® GmbH.



Audi TT Coupé with Audi exclusive customised paint finish in mamba black*

Audi exclusive black gloss package

Audi exclusive leather upholstery and trim (package 1)
in fine Nappa leather in black/calendula yellow with
contrasting stitching in calendula yellow

Audi exclusive extended leather upholstery and trim
in black with contrasting stitching in calendula yellow

Audi exclusive leather controls in black with contrasting
stitching in calendula yellow



*Optional

Your Audi is painted not just once. But four times.

When you choose a paint colour, choose one that best reflects your own personality. But whichever colour you opt for, you can count on the outstanding quality of our painting process. Though no thicker than a human hair, the layer of paint on an Audi is actually made up of four different coats. So not only do you look radiant in your Audi, the car is also optimally protected from environmental influences and wear. For its entire lifetime.



| Solid paint finishes



Ibis white

| Metallic paint finishes

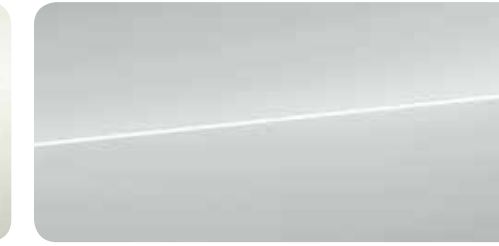

Glacier white, metallic

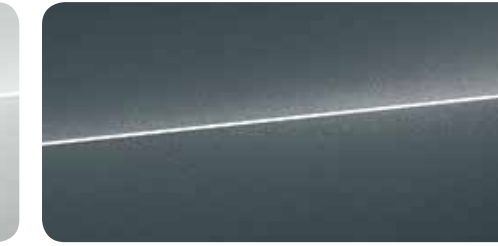

Monsoon grey, metallic



Floret silver, metallic

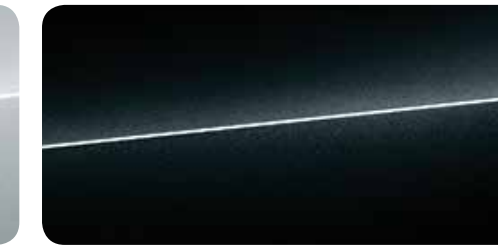

Mythos black, metallic

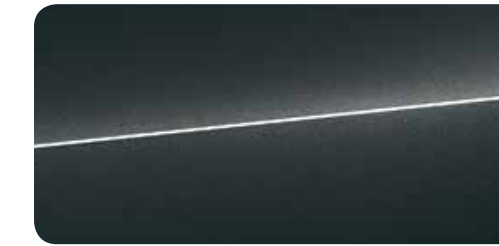

Nano grey, metallic

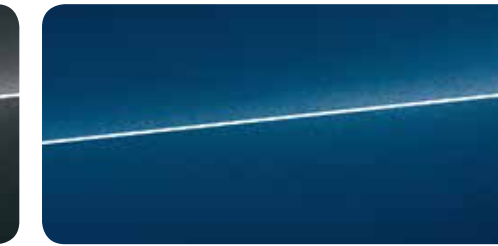

Scuba blue, metallic



Tango red, metallic

| Customised paint finishes



Audi exclusive customised paint finishes
From quattro® GmbH



Quality given form. And a brilliant finish. Audi wheels.

To make sure you have peace of mind for every metre of your drive, Audi puts its wheels through an exacting series of specialised test procedures. Hardness tests, for example, aim for maximum stability, while a Copper Accelerated Salt Spray test – CASS for short – using acetic acid guarantees the greatest possible corrosion protection. Thanks to these and many other measures, we can ensure that every Audi wheel offers maximum quality – even after scores of kilometres.

| Wheels



Cast aluminium wheels
in 5-twin-spoke dynamic design
partly polished,
size 8.5 J x 18 with 245/40 R 18 tyres



Cast aluminium wheels
in 20-spoke V design*
size 8.5 J x 18 with 245/40 R 18 tyres

*Optional

Premium quality you can rely on.

You have a special place in your Audi. Exclusive comfort can be felt on the front and rear seats: thanks to high-quality materials and first-class workmanship. No matter which seat upholstery you choose and whether you prefer sport seats or S sport seats for dynamic driving: you're sitting in the right place.



Sport seats, front 1



S sport seats, front 2

| Leather



Milano leather, black

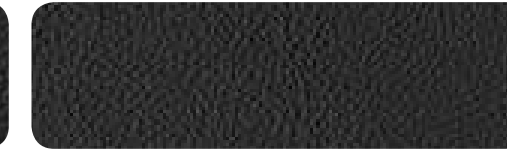

Fine Nappa leather, black



Alcantara/leather, black



Fine Nappa leather, rock grey

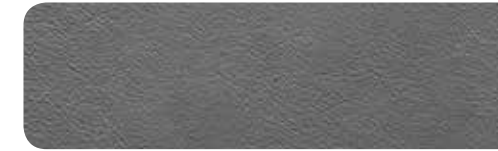

Alcantara/leather, rock grey



Fine Nappa leather, rotor grey

In conjunction with S line sport package



Fine Nappa leather, palomino brown

| Coloured interior elements^{1*}



Haptic coat, black

In conjunction with S line sport package



Finish coat, metal grey



Chrome coat, slate grey

Available only in conjunction with Audi design selection murillo brown or admiral blue



Finish coat, bronze



Coloured interior elements

on the side seat trims, the striking handle on the centre console as well as the inner rings of the vents emphasise the interior design. Colour can be chosen depending on seat upholstery.

| Audi design selection*



Fine Nappa leather murillo brown/steel grey

In diamond pattern



Fine Nappa leather, admiral blue/anthracite

In diamond pattern

| Audi exclusive



Audi exclusive leather upholstery and trim¹

Individual choice of colour for leather/stitching

| Seat options

1 Sport seats, front

2 S sport seats, front

¹ Available only with S sports seats.

*Optional

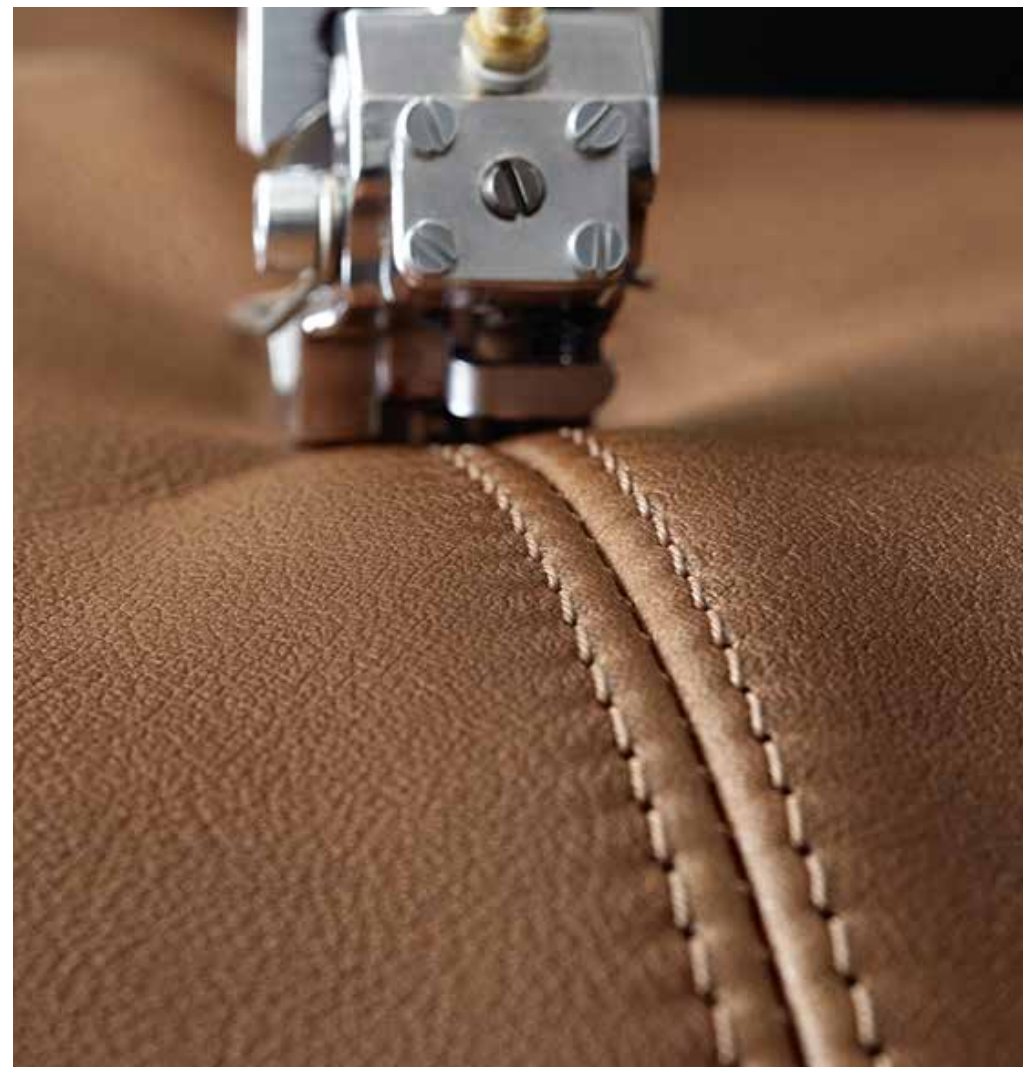

Fixated on quality.

With Audi seats, you can rely not only on elegant materials and top-class workmanship, but also on comprehensive testing procedures as well. Audi tests the quality of all seat leather in its own laboratory, for instance. 45 tests are used to determine the durability alone. Clamped in automatic jigs, the leather samples have to show how evenly they stretch, where they start to tear and when they start to develop folds, how abrasion proof and flame resistant they are. Only leather that passes all the tests with flying colours is used for Audi seats.

*Optional

| Leather upholstery and trim

Alcantara/leather combination*

Exclusive, sporty look for sport seats; high seating comfort and a good seating climate thanks to rapid temperature equalisation; particularly hard-wearing, easy to clean and resistant to wear and tear. The Alcantara seat centre panels provide good support, making them especially suitable for dynamic driving styles. The side bolsters made from the finest leather complete the seat.

For sport seats, front:
seat centre panel and door trim inserts in Alcantara, black
seat side bolsters, head restraints and centre armrest, front (if ordered) in leather, black

For S sport seats, front:
seat centre panel and door trim inserts in Alcantara, black or rock grey
seat side bolsters, head restraints and centre armrest, front (if ordered) in leather, black or rock grey
seat centre panel with diamond pattern

Milano leather

Extremely hard-wearing and durable leather that gives a high-quality impression with its fine, grained surface. Fully penetrated with dye and tanned without the use of chromium, the leather provides outstanding surface protection thanks to the painted coat.

For sport seats, front:
seat centre panel, seat side bolsters, head restraints and centre armrest, front (if ordered) in Milano leather, black
door trim inserts in synthetic leather
seat backrest and rear seat bench partly in synthetic leather

Fine Nappa leather*

High-quality, supple leather with a balanced lacquer coat. It has air-permeable properties thanks to its natural surface, thereby contributing to a pleasant seating climate. The leather is extremely hard-wearing, durable and resistant to fading. Its fine grain underlines its exclusive character.

For S sport seats, front:
seat centre panel, seat side bolsters, head restraints and centre armrest, front (if ordered), as well as door trim inserts in fine Nappa leather, black, rock grey or palomino grey
seat centre panel with diamond pattern
rear seat bench partly in synthetic leather

| Cloth/Leather packages

Leather package*

Armrests in the doors, door pull handles and trim on the centre console in black leather.

Extended leather package*

Armrests in the doors, door pull handles and trim of the centre console in leather, black or colour coordinated to the respective interior colour, as well as steering wheel collapsible collar trim and instrument panel cover in leather, black.

Audi exclusive Alcantara/fine Nappa leather upholstery and trim*

For S sport seat: seat side bolsters and head restraints in fine Nappa leather, seat centre panel and door trim inserts in Alcantara; floor mats, black with coloured leather piping. Individual choice of colour for the Alcantara, the leather and the stitching from the range of Audi exclusive colours.

Audi exclusive fine Nappa leather upholstery and trim*

For S sport seat: seat centre panel, seat side bolsters and head restraints in fine Nappa leather, door trim inserts in Alcantara, floor mats, black with coloured leather piping. Individual choice of colour for the leather, the Alcantara and the stitching from the range of Audi exclusive colours.

Audi exclusive extended leather upholstery and trim*

Leather covering for armrests in the doors, the centre console and instrument panel cover. Individual choice of colour for the leather and the stitching from the range of Audi exclusive colours.

| Seat comfort



Front seats, electrically adjustable

For sport seats and S sport seats with electrical adjustment of seat height, fore/aft position as well as seat and backrest angle, including 4-way lumbar support; for S sport seats additionally with manual adjustment of seat depth.



Centre armrest, front*

Adjustable angle and adjustable lengthways, including additional hinged cup holders.

4-way lumbar support for the front seats

Electric, with horizontal and vertical adjustment.

Pneumatic adjustment of the backrest side bolsters**

Front seats, electrically adjustable, and pneumatic adjustment of the backrest side bolsters and pneumatic lumbar support.

| Seats in the rear



Rear seat backrest, folding

can be split-folded 50:50 or fully.

Experience fascination. Down to the last detail.

Exclusive ambience is a question of style. Your style. A style you can refine right down to the last detail. Create tangible accents with high-quality Audi inlays. Take pleasure in the fine aluminium detailing, partly embossed, partly brushed. Harmoniously integrated into the interior. Exuding a sporty attitude. Creating an ambience that accentuates the dynamic presence of your Audi in the interior too.



| Inlays

for centre console and inlays on the door pull handle



Finish coat, metal grey*

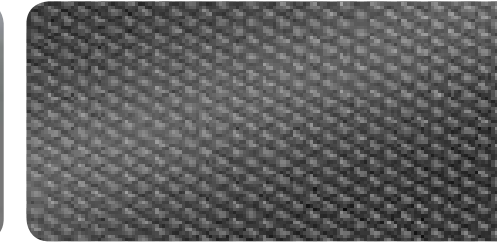

Aluminium drift anthracite*

Available only in conjunction with Audi design selection murillo brown or admiral blue.



Matte brushed aluminium*

In conjunction with S sports seats

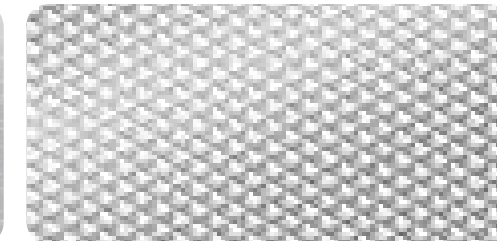

Aluminium drift silver

*Optional

| Headlights

High-beam assist*

Improves the driver's visibility and ensures a more relaxed drive thanks to the extra comfort and convenience. Depending on the traffic situation, the high beam is automatically switched on or off. Working within system limits, it automatically detects the headlights of oncoming traffic, the rear lights of other road users and light sources from built-up areas.



Light/rain sensor

Automatic control of lights-on function, windscreen wipers and the coming home/leaving home function: delayed switch off/automatic switch on of headlights, rear and number plate lights, and in conjunction with xenon plus the LED daytime running lights when parking/opening the vehicle; includes windscreen with grey strip along the top edge.

LED headlights

Near daylight illumination of the road for increased safety and comfort with low power requirements and a long service life; excellent recognition by other road users thanks to the striking TT lighting pattern with daytime and night-time design; consists of dipped beam, high beam, combined daytime running light, position light and indicator function, static turning light as well as all-weather light and motorway light function all using LED technology with automatically increased headlight range from a speed of approximately 110 km/h. The headlights also have different light distribution modes which are activated depending on the vehicle speed: motorway light and country light.

Audi Matrix LED headlights*

The innovative technology with a combination of camera system and LED light sources enables adaptive control of the light distribution. If other road users are detected, the system selectively dips the area affecting the current position of these vehicles, the rest remains in high beam mode. This means maximum illumination is always available within system limits. The main functions when unlocking the vehicle (coming home/leaving home function), switching on driving light, switching between the respective light patterns and control when oncoming traffic drives past are visible as dynamic processes in the headlight and have been adapted to optimise driver light comfort. The separation between conventional low beam and high beam has been more or less abolished. The familiar convenience functions such as static turning light, all-weather light, dynamic cornering light, variable headlight range control and high-beam assist, junction light as well as motorway and travel mode are all integrated in the LED technology. They permit the near-daylight illumination of the road with minimum power requirements, long service life and excellent recognition by other road users thanks to the crisp Audi lighting pattern with daytime and night-time design. The daytime running lights and the dynamic indicator have been implemented in the same light guide and together make up the striking TT lighting pattern. Including LED rear lights with dynamic indicator and headlight cleaning system.



LED rear lights with dynamic indicator

Same functions as the LED rear lights, but additionally featuring a dynamic and quickly recognisable lighting pattern for the indicators. The segments of the LED light band are illuminated in turn within milliseconds, creating a pulse of light that runs outwards in the direction in which the car is turning. When operated, the indicators send a distinctive, innovative signal to other road users.

Adaptive brake light

Brake light flashes in case of emergency stop to warn following traffic. In addition, the hazard warning light is automatically activated when the vehicle comes to a stop.

| Interior lighting

Interior lighting

Anti-glare lighting in energy-saving and long-lasting LED technology, comprising:

- interior lights with reading lights
- reflected lighting for the centre console
- illuminated glove compartment (bulb)
- footwell lighting
- luggage compartment lighting
- passive door reflectors
- vanity mirrors, illuminated

Lighting package

In addition to the interior lighting, comprising:

- entrance light
- ambient lighting for centre console and door trim
- lighting for door opener, map bag and storage compartment
- active door reflectors

| Exterior design



Audi Singleframe

Chrome-plated trim frame around the radiator grille in matte black



Rear spoiler

Extendable, manually by a push button or automatically from speeds of 120 km/h



Tank cap in aluminium look

Characteristic design with TT embossing and visible screw thread

Exhaust tailpipes

Dual-branch design; chrome-plated trims for exhaust tailpipes

Model name

TT logo on the rear

Audi exclusive black gloss package*

Adds black highlights to the exterior of the Audi Singleframe, the trim strips at the side windows and front and rear bumpers. Execution varies depending on model and equipment.

| Interior design



Door sill trims

with aluminium inlays

*Optional

*Optional

| Interior design



Extended aluminium look in the interior
with pedals and footrest in stainless steel; elements in aluminium look on the window controls and mirror adjustment switch.

| Steering wheels/controls



Audi TT Coupé sport contour leather steering wheel with multifunction plus

in 3-spoke design, flattened at the bottom; with more heavily contoured steering wheel rim and 14 multifunction buttons for the convenient operation of the infotainment features, e.g. audio skip, activation of the voice control system, navigation package or freely programmable buttons; adjustable in height and reach and with full-size airbag; for S tronic® with shift paddles for manual gear changing.

Audi exclusive leather controls*

Leather-covered steering wheel rim, gear/selector lever knob and gear lever gaiter in Audi exclusive leather. Individual choice of colour for the leather and the stitching from the range of Audi exclusive colours. Stitching on the steering wheel rim with special Audi exclusive seam detail.

| Mirrors

Exterior mirror heated, electrically folding and automatically dimming on both sides

including heated windscreen washer jets and automatic kerb-side function for the exterior mirror on the passenger side.

The automatic kerb-side function tilts the exterior mirror on the passenger side downwards when reverse gear is selected, giving the driver a better view of the kerb.

Interior mirror

automatically dimming
with light/rain sensor and windscreen with grey strip.

| Climate control



Deluxe automatic air conditioning

with innovative operating logic in the vents, with integrated display, electronic regulation of air temperature, air flow rate and air distribution; defroster nozzles for the windscreen and side windows; automatic recirculation mode by means of air quality sensor, sunlight-dependent control, air intake control and combined filter; with humidity sensor and key-coded settings.

| Closing systems

Remote control key

unlocks and locks doors, luggage compartment lid and tank flap; including convenience closing/opening of the windows; the engine is started and stopped using the engine start-stop button.

Convenience key*

access authorisation system where the key needs only to be carried with you; the vehicle is unlocked and locked from the outside via sensors on the driver and front-seat passenger door handles. Opening of the luggage compartment lid is possible even when the vehicle is locked. Including optical distinction on the top or bottom of the key.

| Storage/transport

Storage and luggage compartment package

Flexible transport of objects and convenient for travel; comprising storage nets on the back of the front-seat backrests and in the front-passenger footwell, storage compartment under the driver and front-passenger seats and 2 high-visibility vests; in the luggage compartment: 2nd luggage compartment light in LED, luggage compartment net, retaining strap at the side, 12V socket.

Cigarette lighter and ashtray

removable; chrome-plated cover with Audi rings, cigarette lighter replaces the standard 12V socket in the centre console.

| MMI®/navigation

**Audi virtual cockpit**

Innovative, fully digital 12.3-inch instrument cluster for the flexible display of information tailored to the driver's needs such as: vehicle speed/engine speed, map representation, radio/media information etc.; integration of the full MMI® functionalities in the instrument cluster. The Audi virtual cockpit is operated via the multifunction steering wheel and the MMI® control panel or MMI® touch. The VIEW button on the multifunction steering wheel allows you to change between 2 differently sized representations of the round instruments. The display with small instruments allows the onboard computer and MMI® contents to be shown on a large clear area of the display. The configuration of onboard computer values in the rev counter is possible. In conjunction with permanent display of navigation information near the speedometer when route guidance has been activated. The attention assist provides a warning in the Audi virtual cockpit and via acoustic signal if anything indicates that the driver is starting to become inattentive. The system is active between approximately 65 and 200 km/h and can be deactivated.

**MMI® navigation plus with MMI® touch***

Navigation system integrated in the 12.3-inch Audi virtual cockpit
 3D map representation with display of lots of sightseeing information and city models
 MMI® search: free text search with intelligent destination suggestions during entry
 MMI® touch for fast intuitive operation
 e.g. destination entry by means of handwriting recognition as well as free movement and zooming in the map
 Detailed route information: map preview, choice of alternative routes, POIs, lane recommendations, motorway exits, detailed junction maps etc.
 Voice control system with whole-word entry of address in one sentence
 Access to smartphone voice control
 Flash memory for music (10 GB)
 AUX-IN

DVD player (MP3, WMA, AAC and MPEG-4 compatible), can be used for music CDs and video DVDs
 2 SDXC card readers
 Audi music interface
 Bluetooth® interface with hands-free mode and Bluetooth® audio streaming
 Display of emails and messages from mobile phone in selected languages including read-out function

| Entertainment

Audi sound system

Impressive sound thanks to 5-channel amplifier with a total output of 155 watts and 9 loudspeakers including centre speaker and 2 bass speakers in the doors.

Audi music interface

for the connection of portable medial players¹ via USB interface (including charging function) or Wi-Fi; convenient navigation through the music collection with the aid of the MMI® control panel, multifunction steering wheel or voice command.

**Bang & Olufsen® Sound System***

Captivating surround sound reproduction with 12 high-performance loudspeakers including 2 centre speakers and 2 bass speakers in the doors. The 14-channel amplifier has a total output of 680 watts. Reproduction of 5.1 surround sound is possible in conjunction with MMI® navigation plus with MMI® touch. Exclusive loudspeaker covers with aluminium applications and LED accent lighting on the front woofers. The sound is continuously adapted according to the driving and background noises picked up by the microphone.

Light Design Steering wheels/controls Comfort **Infotainment** Assistance systems Technology/safety

| Communication

Bluetooth® interface

allows hands-free calls to be made in the vehicle using the microphone and – depending on mobile phone compatibility – Bluetooth® audio streaming. Bluetooth®-capable mobile phones can be connected to the vehicle via the interface.

**Connectivity package***

combines the following features:

- Audi music interface
- Bluetooth® interface for connecting Bluetooth®-capable mobile phones with Bluetooth® audio streaming
- MMI® touch
- Microphones integrated into the seat belt for the best voice quality in any driving situation

*Optional

*Optional

| Assistance systems

**Park assist***

Automatic steering process during parking. Uses ultrasonic sensors to search for suitable perpendicular and parallel parking spaces. The ideal parking path is calculated for perpendicular parking spaces, and the ideal path for leaving the parking space is additionally calculated for parallel parking spaces. The driver must accelerate, change gears and apply the brakes as well as monitor the parking process. The actual steering action is performed by the system. The display of surroundings warns the driver, depending on the steering angle, of any obstacles at the side of the vehicle by displaying the lane. Assisted parking is now even possible in smaller parking spaces and bend areas. Parking in several moves is supported. Activated via a button on the centre console.

Parking system plus¹

Acoustic and visual front and rear parking system assists with parking and manoeuvring. With selective visual view in the Audi virtual cockpit of the distance to detected objects based on the current steering angle and direction of travel. A white segment indicates a detected obstacle outside the driving path. Red segments represent obstacles in the driving path. The virtual lane display additionally provides guidelines at the sides which are calculated in advance based on the current steering angle, thus supporting comfortable parking and leaving of parking spaces. Measurement is by ultrasonic sensors integrated discreetly in the bumpers; activated when reverse gear is selected, via a button on the centre console and automatically, as soon as the distance to a detected object is less than 90cm.

Cruise control¹

at speeds of 30 km/h and above, the system keeps the set speed constant, provided that engine power and engine braking effect permit it; operated via separate steering column stalk; set speed displayed in the Audi virtual cockpit; including adjustable cruise control.

| Driving dynamics/brakes

**Audi drive select®**

allows vehicle characteristics to be set in the available modes auto, comfort, dynamic, efficiency as well as – in conjunction with MMI® radio or MMI® navigation plus with MMI® touch – individual by adjusting the power steering assistance, engine characteristics, torque distribution with quattro® and further optional equipment. The efficiency mode switches specifically selected systems to a consumption-improved basic setting.

S tronic®

6-speed dual-clutch transmission with electrohydraulic actuation allows for shorter gear-change times and gear changes with virtually no perceptible break in propulsive power. The S tronic® can be manually operated using the shift paddles behind the steering wheel or the selector lever. In automatic mode, there is a choice of programmes – D (Drive) and S (Sport). Includes hill hold assist. When in “D” gear, coasting mode allows an anticipatory driving style and helps to reduce fuel consumption by automatically disengaging when the accelerator is released. It is automatically re-engaged when the footbrake or the accelerator is pressed. Can be activated in Audi drive select – efficiency mode.

quattro®

permanent all-wheel drive with electronically controlled multi-plate clutch on the rear axle and Electronic Differential Lock (EDL); distribution of drive forces depending on the driving situation to each individual wheel for precisely controlled, sporty handling; influence of torque distribution in conjunction with Audi drive select®; quattro® emblem in the Audi Singleframe, on the luggage compartment lid.

Secondary collision brake assist

following an accident, uncontrolled continued vehicle motion is prevented in certain situations. In these cases, secondary collisions can be avoided.

**Electromechanical parking brake**

includes parking brake function when stationary, drive-off assistance function through automatic release when driving away and maximum deceleration action while driving acting on all 4 wheels.

Progressive steering*

enhances the driving dynamics and driving comfort thanks to more direct steering characteristics (e.g. on winding rural roadways or when turning) and reduced steering effort (e.g. when parking and manoeuvring); impressive driving characteristics thanks to a steering ratio based on the steering angle and speed-sensitive power steering assistance, can be set via Audi drive select® (auto/comfort/dynamic).

Electromechanical power steering

combines precision and comfort with exceptional energy-saving technology. The electromechanical steering ensures stability at high speeds whilst being light and precise when parking and manoeuvring.

Brake system

diagonally-split dual-circuit brake system, Antilock Brake System (ABS) with Electronic Brake force Distribution (EBD), Electronic Stabilisation Control (ESC) with brake assist, tandem brake booster, disc brakes front/rear, ventilated at front.

¹Please note: The systems work only within system limits and assist the driver. However, the driver remains responsible for driving the vehicle and is required to be attentive at all times.

*Optional

*Optional

| Technology/safety

Recuperation

economises on fuel through brake energy recovery; kinetic energy is converted into usable electrical energy by increasing the generator voltage when the vehicle is coasting or braking and relieving the generator during subsequent acceleration.

Start-stop system

helps to reduce fuel consumption and CO₂ emissions by automatically switching off the engine when stationary.

Airbags

full-size airbags for driver and front passenger.

Side airbags, front, and head airbag system

front side airbags integrated into the seat backrests and a head airbag system deploy over the side windows to protect the front and rear seat passengers in the event of a side impact.

Integrated head restraint system

increases safety and reduces the danger of whiplash. In the event of a rear-end collision, the design of the front seat better restrains the upper torso and provides stronger support for the head than conventional systems.





Audi Genuine Accessories. As individual as the life you lead.

The Audi TT Coupé: more than just a means of travel. It is also an expression of a whole personality. Unique – partly due to Audi Genuine Accessories. Products designed so that you can personalise an Audi according to your own wishes. Benefit from customised solutions with convincing design and functionality. Because alongside numerous testing procedures, creativity in development and high production standards are just as decisive for Audi Genuine Accessories as for the Audi vehicles themselves. Discover which tailor-made ideas Audi Genuine Accessories have ready for your lifestyle. A few highlights are illustrated here – please contact your Audi partner for more information on the complete range.



Further information can be obtained from the Audi TT Coupé accessories catalogue, at www.audi.com and from your Audi partner.

Cast aluminium winter wheel in 5-arm Falx design, brilliant silver

Striking design, a perfect match for your Audi TT Coupé. In size 7 J x 17 for 225/50 R 17 tyres¹.



Cycle fork mount²

Convenient and easy to use. Lockable. Suitable for bicycles with quick-release front wheel. Also available including front wheel mount. Maximum load capacity 17 kg. Can only be used in conjunction with the carrier unit.

Audi tracking system plus (not illustrated)

enables a stolen vehicle to be located and tracked via GPS/GSM technology in 27 European countries. With automatic driver recognition and intelligent restart inhibitor. For more detailed information, please contact your Audi partner.

Premium textile floor mats and rubber floor mats

Tailor-made for the floor dimensions of the Audi TT Coupé. The floor mats are always fixed at the front using the points provided on the floor area of the vehicle. With TT logo.



¹You will find specifications on the technical characteristics of tyres on page 70. ²Only available for TT Coupé. The fuel consumption and CO₂ emission figures can be found on page 70.

Ski and luggage boxes*

New Audi design with improved aerodynamics thanks to a flat, sporty look. Platinum grey roof box with brilliant black side blade and chrome-plated Audi rings; top-quality, rivet-free look. Can be locked and opened on both sides for convenient loading and unloading. With inner handle for pulling the box closed. Simple quick-attachment system incl. torque restriction. Position moved forward for better access to the luggage compartment. Available in three sizes: 300 l, 360 l (illustrated below) and 405 l. Maximum permissible load 75 kg.

**Roof box bags**

Sturdy yet flexible. And including a watertight floor with a watertight border 5 cm high. The individual bags can be combined in different ways to make optimum use of the Audi roof boxes. Available in 3 sizes: S (43 l), M (76 l) and L (82 l).

*Only available for TT Coupé. When the ski and luggage box is used, the vehicle tailgate cannot be opened fully. The fuel consumption and CO₂ emission figures can be found on page 70.



USB adapter for Audi music interface (not illustrated) for the connection of various Apple iPod and iPhone models and further media players to the optional Audi music interface. Available in different versions. The media player can be operated via the infotainment system. For more detailed information, please contact your Audi partner.

Child seat pad (not illustrated)

matches the design of the child seats and the vehicle interior. Protects the vehicle seats from soiling and any pressure marks caused by the child seats. With 2 practical storage bags. Can be installed with all Audi child seats, including with ISOFIX connection.

Business case

More room for your everyday accessories. The high-quality business case has a storage volume of approximately 14 l – enough space for a 15-inch laptop plus various office utensils. Safe attachment to the rear seat bench or to the front-passenger seat using the 3-point seat belt. Can also be used outside the vehicle as an attractive briefcase.

Audi child seat

can be used facing forwards or backwards. With adjustable seat, integrated safety harness and adjustable head restraint. Cloth cover can be removed and washed, is breathable and gentle on the skin, certified in accordance with Oeko-Tex® standard 100, in the colours Misano red/black and titanium grey/black. Can only be used in conjunction with the ISOFIX base. Suitable for children from 9 to 18 kg (approximately 1 to 4 years). Also available: Audi baby seat for children up to 13 kg (approximately 0 to 12 months) and Audi child seat youngster plus for children from 15 to 36 kg (approximately 4 to 12 years).

**Luggage compartment liner**

Tailor-made protection for the luggage compartment. Washable and sturdy. The all-round edging better protects the luggage compartment floor from leaked liquids.



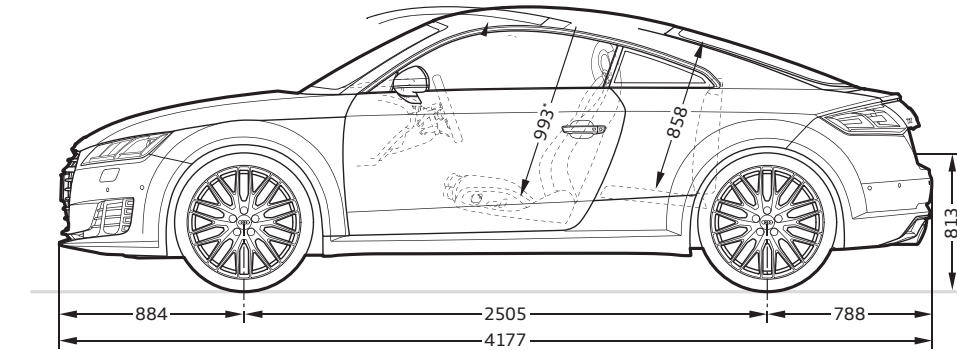

Dimensions in millimetres.

Dimensions are for unladen vehicle weight.
Luggage capacity 305/712 l
(second value with rear set backrest folded down and vehicle loaded up to roof height).
Turning circle approx. 11 m.

*Maximum headroom. **Elbow room width. ***Shoulder room width.

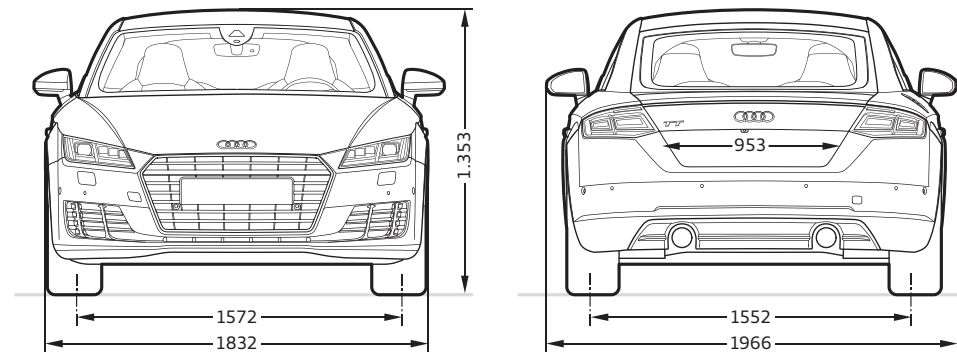
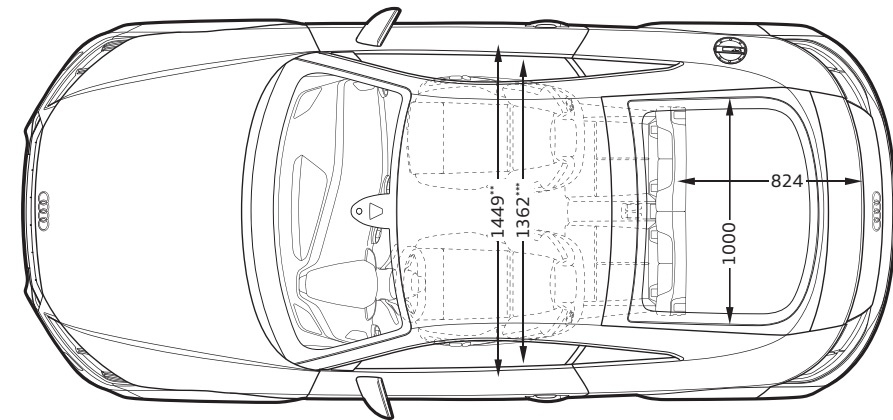

Model	TT Coupé 2.0 TFSI® quattro® (169 kW)
Engine type	4-cylinder inline petrol engine with direct fuel injection, turbocharging and indirect intercooling
Displacement in cc (valves per cylinder)	1,984 (4)
Max. output ¹ in kW at rpm	169/4,500-6,200
Max. torque in Nm at rpm	370/1,600-4,300
Power transmission/wheels	
Drive type	quattro® permanent all-wheel drive
Transmission type	[6-speed S tronic®]
Wheels	Cast aluminium wheels, 8.5J x 18
Tyres	245/40 R18
Weights/capacities	
Unladen weight ² in kg	[1,410]
Gross vehicle weight in kg	[1,735]
Fuel tank capacity, approx. in l	[55]
Performance/consumption³	
Top speed in km/h	[250]
Acceleration 0-100 km/h in s	[5.3]
Fuel grade	Sulphur-free super RON 95 ⁴
Fuel consumption ⁵ km/h	[14.33]

Explanatory notes

- ¹ The figure given was calculated using the specified measuring procedure (current version of UN-R 85).
- ² Unladen vehicle weight includes driver (75 kg) and fuel tank 90% full, calculated in accordance with the current version of Reg. (EU) 1230/2012. Optional equipment may increase the vehicle's unladen weight and drag coefficient, whereupon the possible payload limit and the top speed will be reduced accordingly.
- ³ A vehicle's fuel consumption and CO₂ emissions and deviations from the figures given do not just depend on how efficiently the vehicle uses the fuel, but are also influenced by driving behaviour and other non-technical factors. The figures given for fuel consumption and CO₂ emissions refer to each illustrated standard wheel/tyre combination and may change if different wheel or tyre dimensions are selected. CO₂ is the greenhouse gas primarily responsible for global warming.
- ⁴ We recommend using sulphur-free super unleaded RON 95 fuel complying with DIN EN 228. If this is not available, use sulphur-free regular unleaded RON 91 fuel complying with DIN EN 228; power output will be slightly reduced. Unleaded RON 95 fuel with a maximum ethanol content of 10% (E10) can generally be used. Fuel consumption details refer to operation with RON 95 fuel complying with 692/2008/EC.
- ⁵ ARAI Certified



Responsibility

Living up to our responsibilities is a principle that is firmly anchored in Audi strategy. Alongside commercial success and international competitiveness, our responsibility toward company employees and society as a whole is a key consideration, as is protecting the environment and conserving resources. And what is true in the details – our catalogues are printed on FSC-certified paper – also holds in general: Audi develops cars that are not only sporty and emotive but also ever more efficient. In the long run, Audi wants its products to allow CO₂-neutral

mobility. Seeing to it that production in Audi plants gradually becomes CO₂-neutral is another aspect of our comprehensive approach. Audi is also committed to society – particularly in the fields of education, technology and social projects. At Audi, sustainability is closely linked with how we see the future: the Audi Urban Future Initiative sees Audi working with international experts to get to the root of future urban challenges and trends in mobility.

Discover the world of Audi.



The Audi experience

The fascination of Audi can be experienced in many different ways. Audi City in London, for example, gives you digital access to all models at their actual size and in real time. And of course it is always worth visiting one of the major motor shows. This is where Audi always presents its new models and invites you to take a look at how the future is being shaped with "Vorsprung durch Technik". Anyone interested in seeing how Audi is already putting this into practice will find fascinating insight in the "Vorsprung durch Technik" online special at www.audi.com. But a look back can also be rewarding: at the Audi museum mobile in Ingolstadt, history and high-tech go hand in hand. A total of 130 historic exhibits and state-of-the-art forms



of presentation make for a thrilling symbiosis. Plus, Audi driving experience allows you to live the excitement and countless possibilities of current Audi models. Here, pure driving enjoyment is combined with valuable learning effects. This is ensured by a team of specially trained and highly qualified instructors who provide practical tips to help you optimise your driving skills. All this can now also be enjoyed at the recently opened Audi driving experience center in Neuburg, near Ingolstadt. Facilities here include a circuit of up to 3.4 kilometres that features challenging combinations of bends, a 30,000 m² dynamic driving area and an offroad section where Q models can be put through their paces.



Choosing an Audi means choosing a brand that offers more. More individuality. More exclusivity. More fascination.



Team spirit

Motorsport is a driving force behind the brand. For years Audi has been among the champions in various racing series, for instance the 24 Hours of Le Mans or the DTM German Touring Car Masters. The values that are crucial in many different areas of sport are also central ones for Audi: precision, passion and technology. No coincidence then that Audi has been sponsoring sporting events for

many years. In the world of winter sports, for example, Audi has been the main sponsor of the German Ski Association (DSV) for almost three decades and has also partnered 14 other national alpine teams. In football, we support national and international teams. And Audi is also a partner for the German Olympic Sports Confederation.



